

GA-234-2019

CONTROL JOINTS FOR

FIRE-RESISTANCE RATED SYSTEMS

Control joints in gypsum panel product systems shall be installed where indicated on the plans or specifications. Control joints assist in relieving stresses in assemblies that can result in cracks and joint ridging. Gypsum Association and manufacturer recommendations specify minimum requirements for the installation of control joints. Control joints in the gypsum panel systems shall be specified by the architect or designer where any of the conditions listed below exist.

1. A partition, wall, or ceiling traverses a construction joint (expansion, seismic, or building control element) in the base building structure.
2. Where an interior wall or partition runs in an uninterrupted straight plane exceeding 30 ft (9 m) in length or height.
3. Gypsum panel joints shall not occur within 12 in. (300 mm) of the corners of doorframes and other openings unless installing control joints at these locations.

NOTE: Full-height doorframes are considered control joints.

4. For interior ceilings with perimeter relief, control joints shall be installed so that linear dimensions between control joints shall not exceed 50 ft (15 m) and the total area between control joints does not exceed 2,500 ft² (232 m²).
5. For interior ceilings without perimeter relief, control joints shall be installed so that linear dimensions between control joints shall not exceed 30 ft (9 m) and the total area between control joints does not exceed 900 ft² (84 m²).
6. For exterior ceilings and soffits, control joints shall be installed so that linear dimensions between control joints shall not exceed 30 ft (9 m) and the total area between control joints does not exceed 900 ft² (84 m²).
7. Control joints or intermediate blocking shall be installed where ceiling framing members change direction.
8. A control joint is desired or incorporated as a design accent or architectural feature.

The methods shown for protecting control joints in 1-hour floor–ceiling systems—either direct-attached, furred, or suspended—are applicable to all 1-hour floor–ceiling systems with either wood or metal framing, including, but not limited to, dimensional lumber, wood trusses, wood I-beams, steel bar joists, and steel channel joists.

Individual gypsum panel strips applied behind control joints in ceiling systems shall be at least 48 in. (1,200 mm) long unless the control joint is shorter than 48 in. (1,200 mm).

1-HOUR WALL & PARTITION SYSTEMS

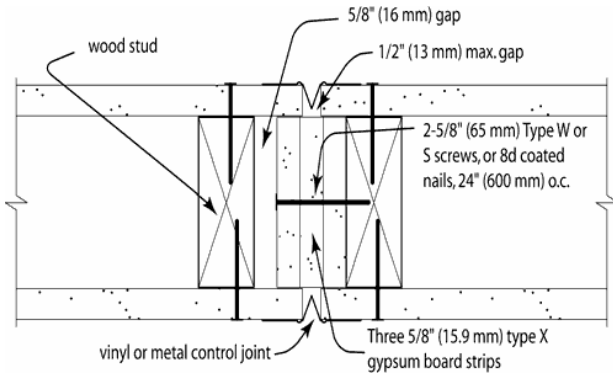

1-HOUR WOOD FRAMED
(WHI-647-3024, 9-20-90)

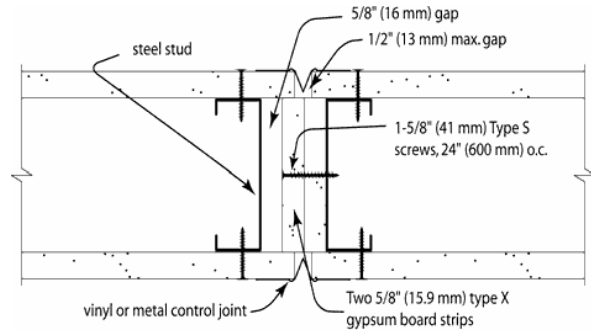

1-HOUR NONCOMBUSTIBLE
(WHI-647-3024, 9-20-90)

2-HOUR WALL & PARTITION SYSTEMS

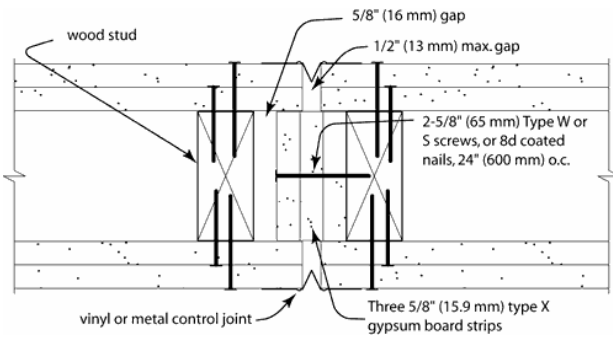

2-HOUR WOOD FRAMED
(WHI-647-3024, 9-20-90)

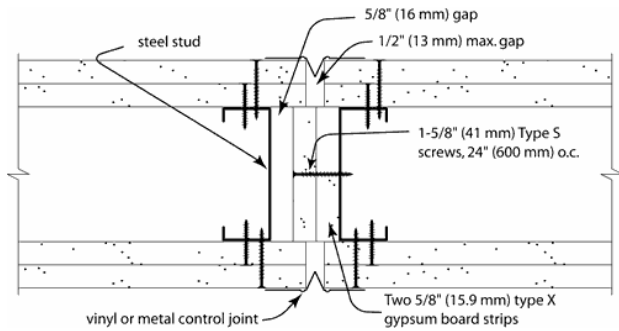

2-HOUR NONCOMBUSTIBLE
(WHI-651-0318.1, 3-20-90)

1-HOUR WOOD-FRAMED FLOOR-CEILING SYSTEMS

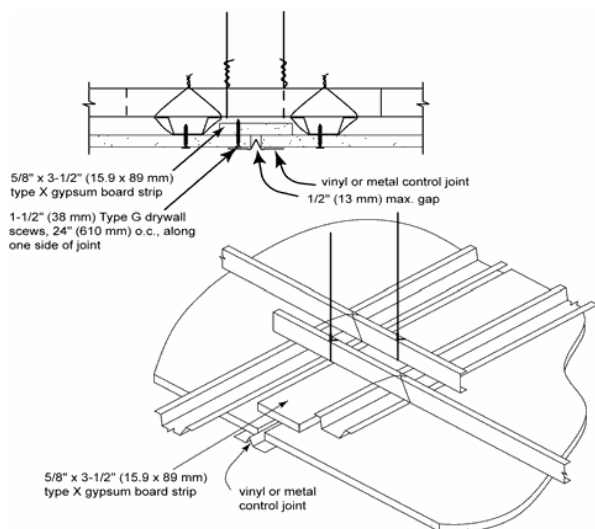

1-HOUR FLOOR-CEILING SYSTEM WITH SUSPENDED CEILING
(UL R4024, 96NK13566, 7-29-96)

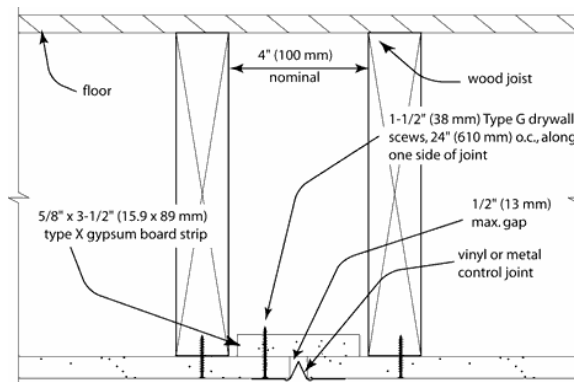

CONTROL JOINT PARALLEL TO FRAMING WITH DIRECT-ATTACHED CEILING
(UL R4024, 97NK13566, 7-29-96)

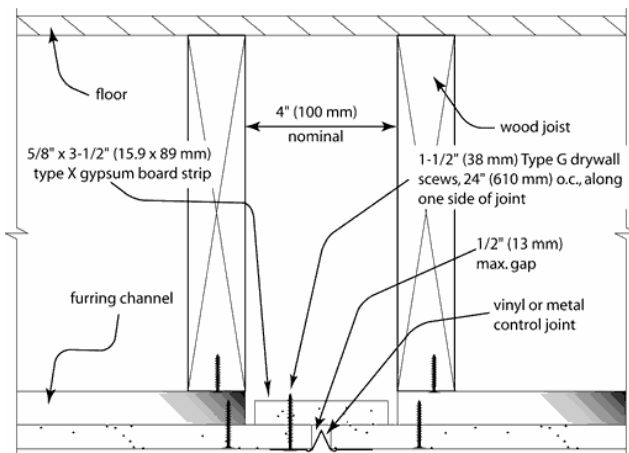

CONTROL JOINT PARALLEL TO FRAMING WITH FURRED CEILING (UL R4024, 97NK2136, 2-7-97)

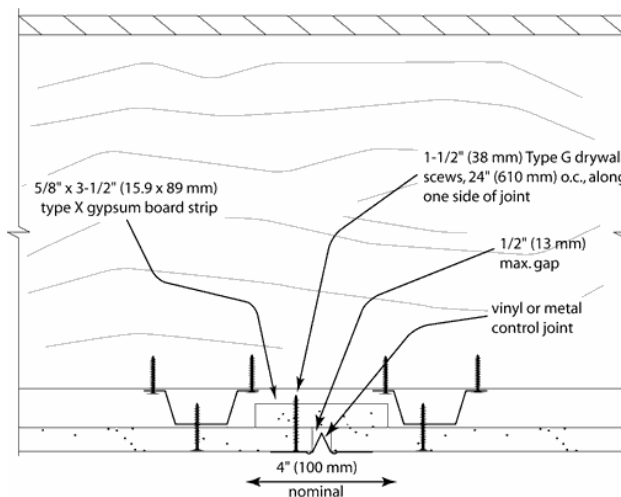

CONTROL JOINT PERPENDICULAR TO FRAMING WITH FURRED CEILING
(UL R4024, 96NK13566, 7-29-96)

Notes:

GYPSUM ASSOCIATION MEMBER COMPANY LIST 2019
AMERICAN GYPSUM COMPANY LLC
CERTAINTEED GYPSUM, INC. / CERTAINTEED GYPSUM CANADA, INC.
CONTINENTAL BUILDING PRODUCTS OPERATING COMPANY, LLC
GEORGIA-PACIFIC GYPSUM LLC
NATIONAL GYPSUM COMPANY
PABCO GYPSUM
UNITED STATES GYPSUM COMPANY / CGC INC.